

MOUNTING CLIP

DRAWING NO:EE-6.3-2

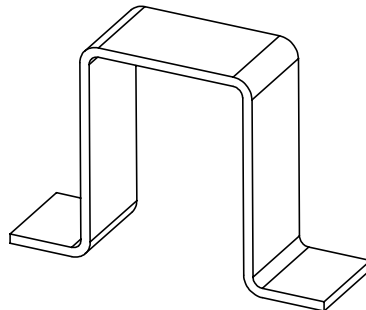
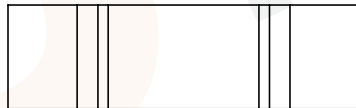
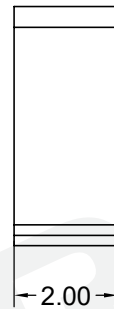
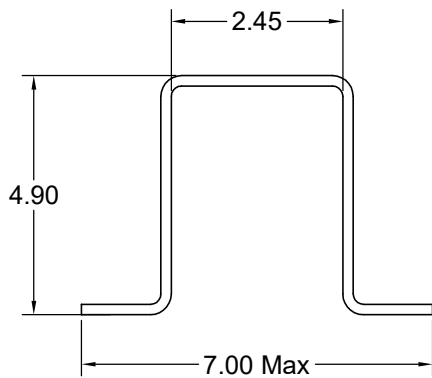

Tolerances unless otherwise specified:
 0<L≤4±0.10 4<L≤16±0.20
 16<L≤45±0.30 45≤L±0.40
 Wall thickness:0.15±0.05 Angle:±1°

Dimensions:
(mm)



REMARK

| | |
|----------------------|----------------------------|
| Mould No.: | Clip Material: C1100 0.15T |
| Code No.: : FAY01269 | UL Recognition: |



Fuan Electronics
 TEL :0086-514-87693589
 EML :sales@fuantronics.net
 WEB:www.fuantronics.net

| | |
|-----------------------|-----------------------------------|
| Make: P.Xiao | Material Number: 224EE0630102 |
| Checked: Beson.zhan | Document/Rev: 00 |
| Approved: Anson. zhan | Date of Recognition: Dec./09/2019 |